

PCI-HB

32-bit/33Mhz PCI Host Bridge Core

This PCI Host Bridge IP core enables data transfers between a host processor and PCI bus based devices.

The bridge allows the host to initiate PCI accesses or to respond to transactions initiated by other PCI devices.

The core complies with the PCI bus specification versions 3.0 and 2.3, and can act as a PCI master and target. Furthermore, it implements PCI bus arbitration, supporting up to seven PCI bus agents, PCI reset signal generation, and all types of PCI transactions provisioned by the standard.

The PCI-HB builds on more than 15 years of CAST PCI IP expertise and has been designed for straightforward reuse, with proven design practices that ensure easy integration and smooth technology mapping. The core is available in synthesizable RTL or as a targeted FPGA netlist, and is delivered with everything required for rapid and successful integration and implementation.

Block Diagram

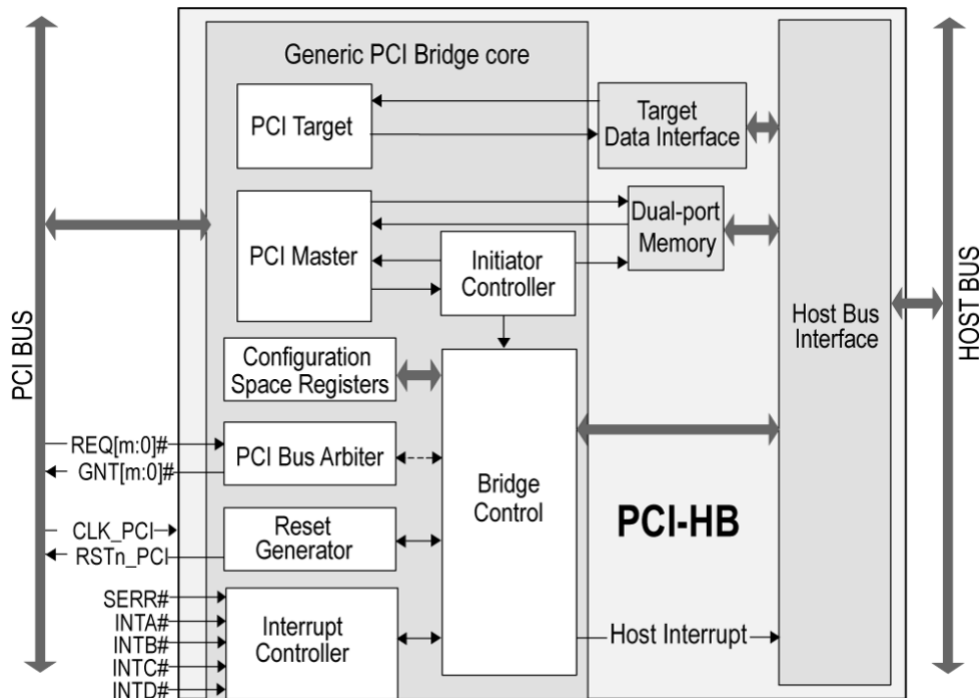

FEATURES

PCI Host Bridge

- Enables data communication between the Host Processor and devices on the PCI bus
- PCI I/O space and memory space are mapped directly to the host-bus memory space
- PCI Interrupt and System Errors are propagated as interrupts to the host
- PCI Configuration registers are accessible from both PCI and host directions
- Asynchronous host and PCI clocks

PCI Interface

- PCI specification 3.0 and 2.3 compliant
 - 33 MHz
 - 32-bit bus width
 - 32-bit address space
 - Parity generation and parity error detection
- PCI Master & Target support all types of transactions:
 - Configuration space read/write
 - Memory space read/write
 - I/O Space read/write
 - Interrupt acknowledge (optional)
 - Special cycles (optional)
- PCI reset generator
- PCI bus arbiter
 - Up to 7 external bus agents
 - Flexible priority schemes
 - Agent malfunction detection and reporting

Deliverables

- VHDL source code or targeted FPGA netlist
- Test-bench & sample simulation and synthesis scripts
- Comprehensive documentation

Support

The core as delivered is warranted against defects for ninety days from purchase. Thirty days of phone and email technical support are included, starting with the first interaction. Additional maintenance and support options are available.

Verification

The core has been verified through extensive simulation, rigorous code coverage measurements and it has been proven in FPGA and ASIC designs.

Deliverables

The core is available in ASIC (synthesizable HDL) and FPGA (netlist) forms, and includes everything required for successful implementation. The ASIC version includes:

- HDL RTL source code
- Sophisticated HDL Testbench
- Simulation script, vectors, expected results, and comparison utility
- Synthesis script
- Comprehensive user documentation, including detailed specifications and a system integration

CAST PCI Cores Family

CAST offers a broad family of PCI cores the members of which along with their basic features are outlined in the following table.

	PCI-T32	PCI-T32MF	PCI-M32	PCI-M32MF	PCI-HB	PCI-HB-AHB	PCI-DHB-AHB
PCI 33 MHz	✓	✓	✓	✓	✓	✓	✓
Host	✗	✗	✗	✗	✓	✓	✓
Master	✗	✗	✓	✓	✗	✗	✓
Target	✓	✓	✓	✓	✗	✗	✓
Multifunction	✗	✓	✗	✓	✗	✗	✗
32bit	✓	✓	✓	✓	✓	✓	✓
64bit	✗	✗	✗	✗	✗	✗	✗
SoC Interface	Generic AXI, AHB, Avalon-MM ₁	Generic AXI, AHB, Avalon-MM ₁	Generic AHB, AXI, Avalon-MM ₁	Generic AXI, AHB, Avalon-MM ₁	Generic AXI, Avalon-MM ₁	AHB	AHB
ASIC Support	✓	✓	✓	✓	✓	✓	✓
FPGA Support	✓ ₂	✓ ₂	✓ ₂	✓ ₂	✓ ₂	✓ ₂	✓ ₂

Notes:

- ✓ : Feature is supported
- ✓ : Feature optionally supported
- ✗ : Feature is not supported
- 1 : SoC interface in grey font can be made available upon request
- 2 : FPGA devices that do not support PCI I/O standard (e.g. Xilinx Virtex-6 and Stratix-V) are not supported