

TSN-SW

Multiport TSN Ethernet Switch

The TSN-SW implements a highly flexible, low-latency, multiport TSN Ethernet switch. It supports Ethernet bridging according to the IEEE 802.1Q-2018 standard and implements the essential TSN timing synchronization and traffic-shaping protocols (i.e. IEEE 802.1AS, 802.1Qav, 802.1Qbv, and 802.1Qbu, 802.1br). Enhanced reliability features can also be supported, using the optional hardware modules for Frame Replication and Elimination for Reliability (IEEE 802.1CB) and Per-Stream Filtering and Policing (IEEE 802.1Qci). Featuring a configurable number of ports, the Layer-2 switch operates in cut-through mode at wire speed and can provide sub-microsecond port-to-port latency. The core is hence suitable for applications with demanding real-time requirements.

The TSN-SW operates efficiently under different usage scenarios and is highly configurable. Users can configure key factors via the core's control registers: the mapping of VLAN priority levels to TSN traffic classes, the traffic scheduling and preemption parameters, the treatment of special frames (i.e. broadcast, unknown, & internal), as well as the VLAN ID and MAC lookup tables used for frame forwarding and filtering. The host system can also switch the mode of operation of each individual port from cut-through to store-and-forward to eliminate the propagation of bad frames at the cost of increased latency. The core otherwise operates autonomously and only requires software assistance at runtime for correct time synchronization; a lightweight ptp/802.1AS software stack comes with the core for that purpose.

The TSN-SW uses standard AMBA® interfaces to ease integration. Its control and status registers are accessible via a 32-bit-wide APB bus, and packet data can be exchanged with the host system via AXI-Streaming interfaces with 32-bit data buses. To further expedite and ease the implementation of customer applications, CAST offers software stacks supporting higher-layer protocols, such as IEEE 802.1Qcc, IEEE 802.1Qca and SNMP, as well as hardware integration and software porting services.

The TSN-SW is designed with industry best practices and is available in synthesizable RTL (Verilog 2001) source code or as a targeted FPGA netlist. Deliverables provide everything required for a successful implementation, including sample synthesis and simulation scripts, an extensive testbench, and comprehensive documentation.

Block Diagram

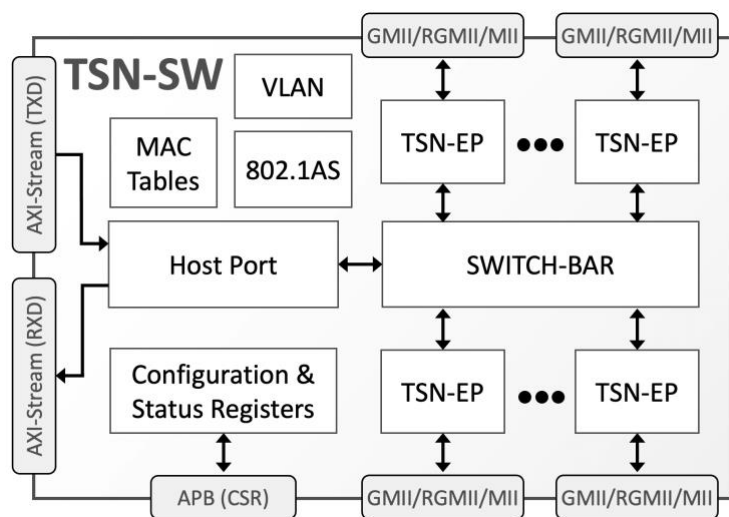

FEATURES

Low-Latency & Flexible Ethernet Switch

- Configurable number of 3 to 15 full-duplex Ethernet ports plus one internal port
 - More than 15 Ethernet ports available upon request
- Layer-2, cut-through switching at wire speed
 - The store-and-forward mode can be enabled per port at run time
- Sub-microsecond port-to-port latency, in cut-through mode
- 10/100/1000 Mbps Ethernet speeds (2.5/10+ Gbps on request)
- 802.1Q-2018 Tagged VLAN support
- Port-based VLAN
- Configurable VLAN-PCP to TSN-queue mapping (QoS by PCP)
- Flexible VLAN and MAC forwarding & filtering
- Configurable VLAN-ID & MAC lookup table for dynamic and static entries
- Automatic aging table
- Untagged ports support
- Port Statistics
- Port mirroring

TSN Features

- IEEE 802.1AS-2020 (requires lightweight software PTP stack)
- Traffic shaping per IEEE 802.1Qav & IEEE 802.1Qbv with eight TSN-Queues
- Frame preemption per IEEE 802.1Qbu and IEEE 802.3br
- Frame Replication and Elimination per IEEE 802.1CB and Per-Stream Filtering and Policing per IEEE 802.1Qci (optionally implemented in hardware)
- Path Control and Reservation per IEEE 802.1Qca, and Enhancements to Stream Reservation Protocol per IEEE 802.1Qcc (optionally implemented in software)

Easy System Integration

- AMBA® SoC Interfaces
 - 32-bit APB control/status interface
 - 32-bit AXI4-Stream for packet data
- MII, GMII or RGMII, and MDIO Ethernet PHY interface per port
- Requires minimal host assistance for initialization and operation
- Provides a wide range of statistics via optionally instantiated counters
- Complete FPGA reference designs available, including lightweight PTP stack sample application software

Applications

The TSN-SW is suitable for implementing TSN Ethernet Endpoints in daisy-chained networks (e.g. ring topologies) requiring robust, low-latency, and deterministic communication. Such networks are used in automotive, industrial control, medical, and aerospace applications.

Support

The core as delivered is warranted against defects for ninety days from purchase. Thirty days of phone and email technical support are included, starting with the first interaction. Additional maintenance and support options are available.

Verification

The TSN-SW has been rigorously verified, hardware-validated, and tested in real-life environments.

It has also been tested and verified at TSN interoperability plugfests organized by the Labs Network Industry 4.0 (LNI 4.0) association and the Industrial Internet Consortium (IIC).

Deliverables

The core includes everything required for successful implementation:

- Verilog RTL source code or targeted FPGA netlist
- Testbenches
- Sample Simulation and Synthesis scripts
- Comprehensive Documentation
- Lightweight PTP stack, easily portable to any other RTOS

Related Products

The core is a member of CAST's family of automotive interface products that includes:

- TSN-EP TSN Ethernet Endpoint IP Core
- TSN-SE: TSN Ethernet Switched Endpoint IP Core
- TSN-VIP TSN Ethernet Verification IP
- LLEMAC-1G Low-Latency 10/100/1000 Ethernet MAC IP core
- CAN 2.0/CAN FD/CAN XL Controller IP core
- CAN 2.0/CAN-FD Verification IP
- LIN 2.2/2.1/2.0 Master/Slave Controller IP core
- SENT/SAE J2716 Transmitter/Receiver Controller IP core