

TSN-EP

TSN Ethernet Endpoint Controller



The TSN-EP implements a configurable controller meant to ease the implementation of endpoints for networks complying to the Time Sensitive Networking (TSN) standards. It integrates hardware stacks for timing synchronization (IEEE 802.1AS) and traffic shaping (IEEE 802.1Qav and 802.1Qbv), frame-preemption (IEEE 802.1Qbu and IEEE 802.3br) and a low-latency Ethernet MAC.

The controller core is designed to enable high-precision timing synchronization and flexible yet accurate traffic scheduling. Requiring minimal software assistance for its initialization, it features extremely low and deterministic ingress and egress latencies, and simplifies the development of time-aware applications. While operating autonomously, the TSN-EP provides the system with timing information (time-stamps, alarms, etc.) that is typically required for the operation of a TSN network endpoint device. Furthermore, it allows the system to define and tune in real time the traffic shaping parameters according to an application's requirements.

The TSN-EP uses standard AMBA® interfaces to ease integration. Its configuration and status registers are accessible via a 32-bit-wide APB bus, and packet data are input and output via 32-bit-wide AXI-Streaming buses.

The TSN-VIP TSN Ethernet Verification IP package is available for this core.

The TSN-EP is designed with industry best practices, and is available in synthesizable RTL (Verilog 2001) source code or as a targeted FPGA netlist. Deliverables provide everything required for a successful implementation, including sample scripts, an extensive testbench, and comprehensive documentation.

Block Diagram

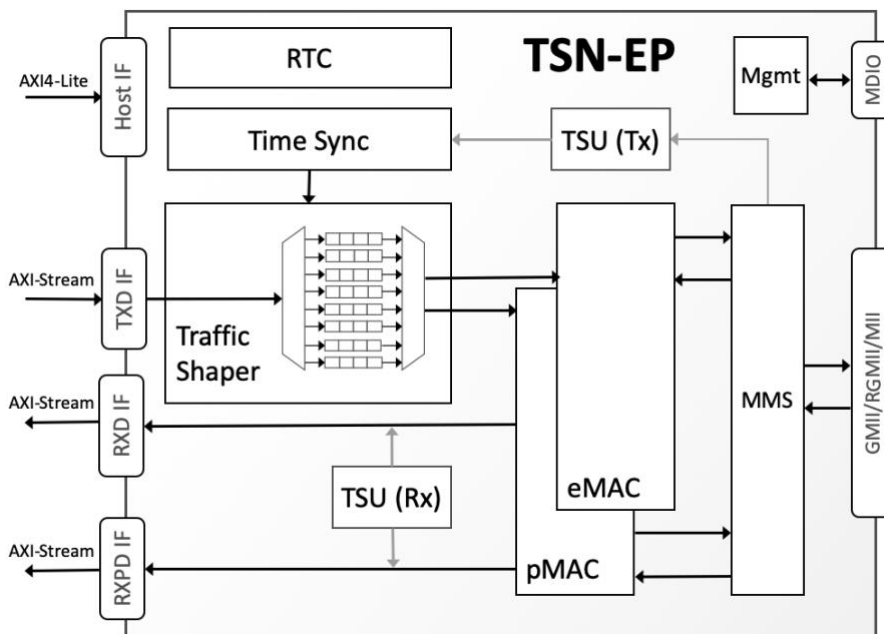

Applications

The TSN-EP is suitable for the implementation of sources of traffic and bridges for TSN Ethernet networks requiring robust, low-latency, and deterministic communication. Such networks are used in automotive, industrial control, and aerospace applications.

FEATURES

Time Synchronization

- Implements IEEE 802.1AS
- Grandmaster or Slave functionality
- Highly accurate synchronization. Accuracy is typically in the order of few tens ns.
- Provides the system with timestamps, periodic event triggers and alarm

Traffic Shaping

- Implements Traffic Scheduling as per IEEE 802.1Qav and IEEE 802.1Qbv
- Implements Frame Preemption as per IEEE 802.1Qbu and IEEE 802.3br
- Supports up to 8 traffic classes, as per VLAN (IEEE 802.1Q)
- Enables bandwidth reservation and allocation per traffic class, and deterministic, low-latency, low-jitter communication for all traffic classes

Low-Latency Ethernet MAC

- Enables high-precision synchronization in TSN networks
 - Egress latency: 10 Tx clock cycles
 - Ingress latency: 6 Rx clock cycles
- 10/100/1000 Mbit/s Ethernet

Easy System Integration

- AMBA/AXI4 Interfaces
 - 32-bit APB for control/status registers
 - 32-bit AXI4-Stream for packet data
- MII, GMII and RGMIII Ethernet PHY interface
- Complete reference designs available for Altera and Xilinx, including sample application software
- Requires minimal host assistance for its initialization

Verification IP

- The TSN-VIP Ethernet Verification IP package is available for this core

Implementation Results

The TSN-EP can be mapped to any Lattice FPGA device (provided sufficient silicon resources are available). The FPGA resources requirements depend on the core configuration. The following are sample results for a small number of core configuration. Please contact CAST to get characterization data for your target configuration and technology.

Family/Device	Configuration*	Logic	Memory
LatticeECP3 LFE3-150EA	4 Traffic Queues 1k Queue Depth RTC, Traffic Shaper	3,700 Slices 4 MULT18	10 EBR
Lattice CertusNX LFD2NX-40	2 Traffic Queues 1k Queue Depth RTC, Traffic Shaper	8,217 LUT4	2 EBR
Lattice CertusPro-NX LFCPNX-100	2 Traffic Queues 1k Queue Depth RTC, Traffic Shaper	8,217 LUT4	2 EBR
Lattice CertusNX LFD2NX-40	8 Traffic Queues 1k Queue Depth RTC, Traffic Shaper, Preemption	29,894 LUT4	2 EBR
Lattice CertusPro-NX LFCPNX-100	8 Traffic Queues 1k Queue Depth RTC, Traffic Shaper, Preemption	29,894 LUT4	2 EBR

*Partial list of configuration parameters

Verification

The TSN-EP has been rigorously verified, hardware-validated, and tested in real-life environments.

It has also been tested and verified at TSN interoperability plugfests organized by the Labs Network Industry 4.0 (LNI 4.0) association and the Industrial Internet Consortium (IIC).

The TSN-VIP TSN Ethernet Verification IP package is also available, to help test the TSN-EP or an SoC containing it.

Support

The core as delivered is warranted against defects for ninety days from purchase. Thirty days of phone and email technical support are included, starting with the first interaction. Additional maintenance and support options are available.

Deliverables

The core includes everything required for successful implementation:

- Verilog RTL source code or targeted FPGA netlist
- Testbenches
- Sample Simulation and Synthesis scripts
- Comprehensive Documentation
- Lightweight PTP stack and device driver for FreeRTOS, easily portable to any other RTOS.

Related Products

The core is a member of CAST's family of automotive interface products that includes:

- TSN-SE TSN Ethernet Switched Endpoint IP core
- TSN-SW: TSN Ethernet Switch IP Core
- TSN-VIP TSN Ethernet Verification IP
- LLEMACE-1G Low-Latency 10/100/1000 Ethernet MAC IP core
- CAN 2.0/CAN FD/CAN XL Controller IP core
- CAN 2.0/CAN-FD Verification IP
- LIN 2.2/2.1/2.0 Master/Slave Controller IP core
- SENT / SAE J2716 Transmitter/Receiver Controller IP core