

# I3C-S

## MIPI I3C Basic Slave Controller



The I3C-S core implements a versatile MIPI® Improved Inter Integrated Circuit (I3C) Slave controller core suitable for any I3C bus topology & compliant with the latest MIPI I3C Basic<sup>SM</sup> specification.

The highly featured slave-only core communicates in Single Data Rate (SDR) mode, but can tolerate High Data Rate (HDR) traffic. It can coexist and communicate with legacy I2C devices, and it can optionally be configured to operate as such in an I3C or I2C bus. The I3C-S needs no firmware support to parse and execute the broadcast or direct Common Command Codes (CCCs) relevant to I3C Basic Slaves. It can be assigned a Dynamic Address by the bus master or use its legacy I2C static address, it supports Hot Join and is capable of generating In-Band Interrupts when directed by the host to do so.

Designed for easy integration, the I3C-S can operate in two different modes. Under *normal mode*, data from private I3C or legacy I2C write transfers are stored to a FIFO and made available to the host via an APB Slave interface. In a similar way, the host provides data to be used for private I3C or legacy I2C read transfers via the core's APB slave interface. Alternatively, the core can operate in I3C-to-AHB *bridging mode*, where it autonomously converts private I3C or legacy I2C transfers to accesses on its AHB master port using a simple yet configurable over-I3C protocol. Under the I3C-to-AHB bridging mode, the core needs no software assistance and provides the I3C-master access to the local AHB bus, enabling remote monitoring, configuration, debug, or data exchange. The selection between normal and bridging operation modes is under software control via the core's control register.

The highly flexible core offers synthesis-time and run-time configuration options, which allow adapting its size and behavior to the application requirements. For example, the AHB-master interface and the clock domains synchronizers can be removed at synthesis to reduce the core's silicon footprint. During run-time, the I3C private data and I2C traffic can be bridged to the core's AHB-master interface or transferred to and from the host via the core's slave APB interface. Also, parameters defining the CCCs processing (e.g. own-address, provisional ID, acknowledge for different type CCCs), the over-I3C protocol (i.e. number address bytes, max number of data bytes) and the AHB-master port behavior (e.g., AHB burst type & address wrapping) are all run-time configurable via the core's registers.

The I3C-S core adheres to the industry's best coding and verification practices to ensure trouble-free implementation in ASIC or FPGA technologies. Technology mapping, constraining, and scan insertion are straight-forward, as the core contains no multi-cycle or false paths and uses only rising-edge-triggered D-type flip-flops, no tri-states, an asynchronous reset line per clock domain, and clean clock domain crossing modules. Its reliability and low risk have been proven through rigorous verification and FPGA validation.

## Applications

The I3C-S core can add economical and low-power I3C data transfer capabilities to sensors, actuators, power regulators, analog front-ends, microcontroller peripheral devices, microcontrollers, or even FPGA devices and designs.

## FEATURES

### I3C Features

- I3C Basic, up to 12.5 Mbit/s, SDR-Capable and HDR-Tolerant Slave
- Autonomous processing of all Broadcast and Direct Common Command Codes (CCCs) relevant to an I3C Basic slave
- Hot-Join Mechanism
- In-Band Interrupts
- I3C Bus and Device Characteristic Registers (BCR & DCR)
- Dynamic Addressing Assignment
- Optional operation as a legacy I2C device, and interoperable with legacy I2C devices
  - Supports I2C static addressing, I2C messaging, and a 50ns spike filter

### Easy to Use & Integrate

- Run-time selectable operation modes:
  - Autonomous I3C-to-AHB bridge
  - Firmware-assisted, I3C controller exchanging data with the host via APB-accessible registers or implementing a custom over-I3C protocol
- Standardized AMBA interfaces
  - APB-Slave for register access
  - AHB-Master (when I3C-to-AHB bridging mode is enabled)
- Independent clocks for APB, AHB and I2C with clean clock domain crossing
- Fully synchronous, scan-ready, LINT-clean design

### Configuration Options

- Synthesis-Time: FIFO sizes, AHB-master Interface and Clock Synchronizers instantiation
- Run-Time: Data traffic source & target selection (AHB-master I/F or APB Accessible Registers & FIFOs), and FIFO Interrupt threshold

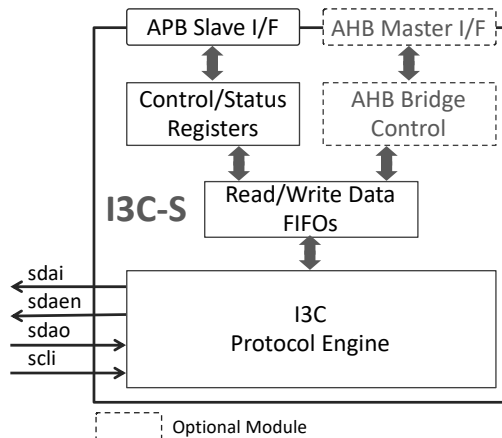

## Implementation Results

The I3C-S can be mapped to any Intel FPGA device, provided sufficient resources are available. The following table provides sample silicon resources utilization data. Please contact [CAST](#) to get characterization data for your target configuration and technology.

FPGA Family	Configuration	Resources
Cyclone V	Minimum	1,182 ALMs
	Full, without CDC, 32x16 FIFOs	2,520 ALMs
	Full, with CDC, 32x16 FIFOs	2,667 ALMs
Stratix V	Minimum	1,189 ALMs
	Full, without CDC, 32x16 FIFOs	2,533 ALMs
	Full, with CDC, 32x16 FIFOs	2,674 ALMs
Arria 10GX	Minimum	829 ALMs
	Full, without CDC, 32x16 FIFOs	1,680 ALMs
	Full, with CDC, 32x16 FIFOs	1,739 ALMs
Max 10	Minimum	1,461 LEs
	Full, without CDC, 32x16 FIFOs	3,995 LEs
	Full, with CDC, 32x16 FIFOs	4,617 LEs

## Support

The core as delivered is warranted against defects for ninety days from purchase. Thirty days of phone and email technical support are included, starting with the first interaction. Additional maintenance and support options are available.

## Verification

The core has been rigorously verified through extensive synthesis, place and route, simulation runs, with in-house and 3<sup>rd</sup> party verification. The core is silicon-proven.

## Deliverables

The core is available in synthesizable RTL and FPGA netlist forms. It ships with everything required for successful implementation, including:

- Verilog RTL source code
- Post-synthesis EDIF (netlist licenses)
- Testbenches for behavioral and post-synthesis verification
- Simulation & Synthesis scripts
- Documentation

## About the MIPI I3C Basic Specification

The MIPI I3C Basic specification is a subset of the MIPI I3C Specification that is publicly accessible and intended to be implementable by non-MIPI organizations under a RAND-Z license.

The Royalty-free MIPI I3C Basic provisions a multidrop two-wire serial bus operating up to 12.5MHz that provides many of the I3C protocol innovations, including in-band interrupts, dynamic address assignment and backward compatibility with I2C.

Learn more at [MIPI I3C official web page](#).