

H264-LD-BP

Low-Power AVC/H.264 Baseline Profile Decoder



The H264-LD-BP IP core implements a silicon and energy efficient hardware video decoder able to process H.264 streams produced by the H264-E-BPS, H264-E-BPF, and H264-E-BIS video encoder cores available from CAST.

The H264-LD-BP is extremely small, requiring less than 70k gates and about 60k bits of internal memory. Its small silicon footprint, low bandwidth requirements, and zero software-overhead enable extremely cost-effective and low-power ASIC and FPGA implementations.

The H264-LD-BP is designed for straightforward, trouble-free SoC integration. It operates on a stand-alone basis such that decoding proceeds without any assistance or input from the host processor. The decoder's memory interface—used to store reconstructed video data—is extremely flexible: it operates on a separate clock domain, is independent from the external memory type and memory controller, and is tolerant to relatively large latencies. The decoder reports decompressed video parameters, detects and reports bit stream errors to the system, and simplifies video cropping at its output. The core is optionally delivered with a raster-to-block converter, and wrappers for AMBA® AHB, AXI, or AXI-Streaming buses are available.

Customers can further decrease their time to market by using CAST's integration services to receive complete video encoding/decoding subsystems. These integrate the decoder core with video encoders, video and networking interface controllers, networking stacks, or other CAST or third-party IP cores.

The H264-LD-BP IP core is designed using industry best practices and has been multiple times production proven. Its deliverables include a complete verification environment and a bit-accurate software model.

Block Diagram

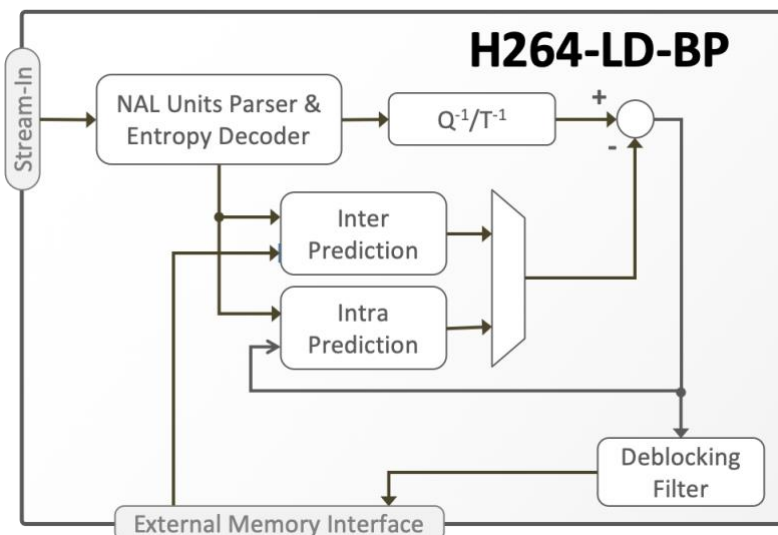

FEATURES

Low-power AVC/H.264 decoder, with small silicon footprint; optimized for low-latency, low-bit-rate video streaming

- Decodes streams produced by the H264-E-BPS, H264-E-BPF, and H264-E-BIS cores

Video Formats

- Progressive or Interlaced, 4:2:0 YCbCr with 8 bits per color sample
- Single-channel SD, ED, and Full-HD capable even in low-cost FPGAs
- Optional multichannel decoding

Small and Low-Power

- Less than 70k Gates and about 60k bits of RAM
- Less than half the typical silicon footprint and small external memory bandwidth mean it uses less power than competitive hardware H.264 decoders
- Consumes much less power than any equivalent software or software-hardware decoder

Ease of Integration

- Zero CPU overhead, stand-alone operation
- Flexible external memory interface. Uses a separate clock, is independent of memory type and tolerant to latencies
- AMBA® Interface Options: DMA-capable AMBA® AHB, AXI or AXI-Streaming

Supported Coding Tools

- I and P Slices
- Single Reference Frame
- Motion vector up to $-32.00/+31.75$ pixels down to $\frac{1}{4}$ pel accuracy
- All intra16x16 and most intra 4x4 modes
- Multiple slices per frame
- Block skipping
- Deblocking filter

Silicon Resources Utilization

The H264-LD-BP BP can be mapped to any Intel/Altera Family (provided sufficient silicon resources are available) and optimized to suit the particular project's requirements. The following table provides sample resource utilization data for different Intel/Altera Device Families.

	Area	Memory Bits	DSPs / MULs
StratixV	4k ALMs	59,278	2
Arria10	4k ALMs	59,278	2
CycloneV	4k ALMs	59,278	2
Max10	10K LEs	59,364	2

Multiple H264-LD-BP cores can be combined to decode streams produced by the H264-E-BPF core. The following table indicates the number of H264-LD-BP cores that would be required for different video formats in different Altera families.

	480p30	720p30	720p60	1080p30	1080p60
StratixV	✓ (1)	✓ (1)	✓ (2)	✓ (2)	✓ (3)
Arria10	✓ (1)	✓ (1)	✓ (2)	✓ (2)	✓ (3)
CycloneV	✓ (1)	✓ (2)	✓ (3)	✓ (3)	✗
Max10	✓ (1)	✗	✗	✗	✗

Note: List of video formats is not exhaustive.

H.264 Cores Family

The H264-LD-BP is one member of the family of H.264 cores that CAST offers. The low-latency H264-D-BP and the encoders summarized in the following table are also available. .

H.264 ENCODER CORES	H264-E-BIS Intra-Only Baseline Profile	H264-E-BPS Low-Power Baseline Profile	H264-E-MPS Low-Power Main Profile	H264-E-CFS Ultra-Low-Power Baseline Profile	H264-E-HIS Intra-Only High Profile	H264-E-BPF Ultra-Fast Baseline Profile
Cycles/Pixel	4	4	4	4	2.5	2 or 1
Silicon Resources *	Very Small	Small	Small	Small	Moderate	Moderate-High
Profile	Constrained Baseline	Constrained Baseline	Main	Constrained Baseline	High 10 Intra	Constrained Baseline
Slices Types	IDR	IDR, P	IDR, P	IDR, P	IDR	IDR, P
Chroma Formats	4:2:0	4:2:0	4:2:0	4:2:0	4:2:0	4:2:0
Bits per sample	8	8	8	8	8, 10	8
Progressive/Interlaced	✓ / ✓	✓ / ✓	✓ / ✗	✓ / ✗	✓ / ✗	✓ / ✓
Multiple video channels	Optional	Optional	Optional	Optional	✗	Optional
CAVLC / CABAC	✓ / ✗	✓ / ✗	✗ / ✓	✓ / ✗	✓ / ✗	✓ / ✗
CBR and VBR	✓	✓	✓	✓	✗	✓
Intra-Refresh	N/A	✓	✓	✓	N/A	✓
Multiple Slices	✓	✓	✓	✓	✗	✓
Compressed Frame Store	✗	✗	✗	✓	N/A	N/A

* Very Small <100k Gates, Small < 200k Gates, Moderate < 500K Gates, and High > 500KGates

Evaluation

Potential customers can readily evaluate the video decoder's low latency characteristics by using the [Video over IP](#) reference design with the compressed stream captured over Ethernet, and the decoded video driving an HDMI interface.

Deliverables

The core deliverables include everything required for successful implementation:

- Targeted netlist for Intel FPGAs
- Sophisticated self-checking Testbench
- Synthesis scripts.
- Simulation script, vectors, and expected results.
- Comprehensive user documentation.