

# CAST

## H264-LD-BP

### Low-Power AVC/H.264 Baseline Profile Decoder

The H264-LD-BP IP core implements a silicon and energy efficient hardware video decoder able to process H.264 streams produced by the H264-E-BPS, H264-E-BPF and H264-E-BIS video encoder cores available from CAST.

The H264-LD-BP is extremely small, requiring less than 70k gates and about 60k bits of infernal memory. Its small silicon footprint, low bandwidth requirements, and zero software overhead enable extremely cost-effective and low-power ASIC and FPGA implementations.

The H264-LD-BP is designed for straightforward, trouble-free SoC integration. It operates on a stand-alone basis such that decoding proceeds without any assistance or input from the host processor. The decoder's memory interface—used to store reconstructed video data—is extremely flexible: it operates on a separate clock domain, is independent from the external memory type and memory controller, and is tolerant to large latencies. The decoder reports decompressed video parameters, detects and reports bit stream errors to the system, and simplifies video cropping at its output. The core is optionally delivered with a raster-to-block converter, and wrappers for AMBA® AHB, AXI, or AXI-Streaming buses are available.

Customers can further decrease their time to market by using CAST's integration services to receive complete video encoding/decoding subsystems. These integrate the decoder core with video encoders, video and networking interface controllers, networking stacks, or other CAST or third-party IP cores.

The H264-LD-BP IP core is designed using with industry best practices and has been multiple times production proven. Its deliverables include a complete verification environment and a bit-accurate software model.

#### Block Diagram

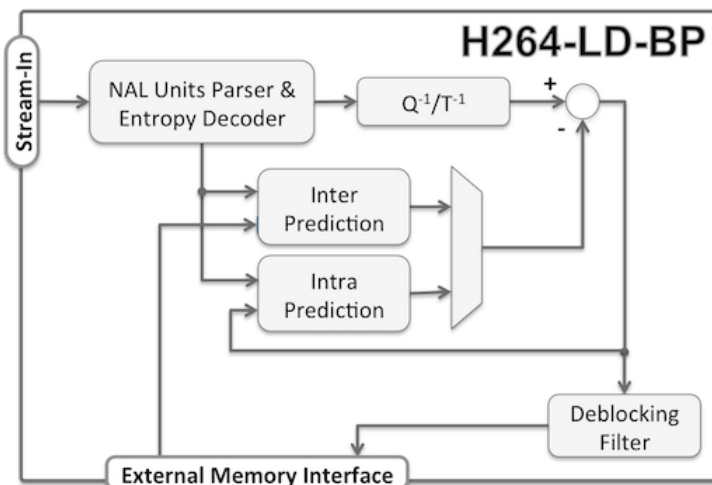

#### Features

Low-power AVC/H.264 decoder, with small silicon footprint and optimized for low-latency, low-bit-rate video streaming

- Decodes streams produced by the H264-E-BPS, H264-E-BPF, and H264-E-BIS cores

#### Video Formats

- Progressive or Interlaced, 4:2:0 YCbCr with 8 bits per color sample
- Single-channel SD, ED, and Full-HD capable even in low-cost FPGAs
- Optional multichannel decoding

#### Small and Low-Power

- Less than 70k Gates and about 60k bits of RAM
- Less than half the typical silicon footprint and small external memory bandwidth mean it uses less power than competitive hardware H.264 decoders
- Consumes much less power than any equivalent software or software-hardware decoder

#### Ease of Integration

- Zero CPU overhead, stand-alone operation
- Flexible external memory interface. Uses separate clock, is independent of memory type and tolerant to latencies
- AMBA® Interface Options: DMA-capable AMBA® AHB, AXI or AXI-Streaming

#### Supported Coding Tools

- I and P Slices
- Single Reference Frame
- Motion vector up to -32.00/+31.75 pixels down to ¼ pel accuracy
- All intra16x16 and most intra 4x4 modes
- Multiple slices per frame
- Block skipping
- Deblocking filter

## Silicon Resources Utilization

The H264-LD-BP synthesizes to less than 70k gates and also requires about 60 Kbits of internal memory.

The H264-LD-BP can be mapped to any ASIC technology and optimized to suit the particular project's requirements. The following table provides sample implementation data for a single H264-LD-BP.

Target Technology	Logic (kGates)	Memory Bits	Freq. (MHz)	Throughput (Mpixels/sec)	Video Format
TSMC 16nm	55k	58K	1,000	250	UHD/4k@30fp
TSMC 40nm	60k	58K	500	200	1080p60

These sample implementation figures do not represent the highest speed or smallest area possible for the core. Note that under certain conditions two or more H.264-LD-BP cores can be combined to decode streams produced by the H264-E-BPF core.

## H.264 Cores Family

The H264-LD-BP is one member of the family of H.264 cores that CAST offers. The following tables summarize the family members and highlight their basic features.

### H.264 ENCODER CORES

	LOW POWER ENCODERS			FAST ENCODER	ULTRA-FAST ENCODER
	H264-E-BIS Low-Power Intra-Only Base-line Profile Enc.	H264-E-BPS Low-Power Baseline Profile Encoder	H264-E-MPS Low-Power Main Profile Encoder	H264-E-HIS Intra-Only High Profile Encoder	H264-E-BPF Ultra-Fast Baseline Profile Encoder
Throughput (cycles/pixel)	4	4	4	2.5	2 or 1
Silicon Resources *	Very Small	Small	Small	Moderate	Moderate-High
Profile	Constrained Baseline	Constrained Baseline	Main	High 10 Intra	Constrained Baseline
Slices Types	IDR	IDR, P	IDR, P	IDR	IDR, P
Chroma Formats	4:2:0	4:2:0	4:2:0	4:2:0	4:2:0
Bits per sample	8	8	8	8, 10	8
Progressive/Interlaced	✓/ ✓	✓/ ✓	✓ / ✗	✓ / ✗	✓/ ✓
Multiple video channels	Optional	Optional	Optional	✗	Optional
CAVLC / CABAC	✓ / ✗	✓ / ✗	✗ / ✓	✓/ ✗	✓ / ✗
CBR and VBR	✓	✓	✓	✗	✓
Intra-Refresh	N/A	✓	✓	N/A	✓
Multiple Slices	✓	✓	✓	✗	✓

\* Very Small <100k Gates, Small < 200k Gates, Moderate < 500K Gates, and High > 500KGates

### H.264 DECODER CORES

	H264-D-BP Low Latency Baseline Profile Decoder	H264-LD-BP Low Power Baseline Profile Decoder
Profile	Constrained Baseline	Constrained Baseline
Profile Compatibility	Full	Limited to streams from the H264-E-BPS/BPF, BIS cores
Additional Features	✗	Interlaced with Main Profile Syntax
Throughput (cycles/pixel)	2.5	4
Silicon Resources	Moderate	Small

\* Very Small <100k Gates,, Moderate < 500K Gates

## Evaluation

Potential customers can readily evaluate the video decoder's low latency characteristics by using the [Video over IP](#) reference design with compressed stream captured over Ethernet, and decoded video driving an HDMI interface.

## Deliverables

The core deliverables include everything required for successful implementation:

- Source-code HDL (Verilog or VHDL) (ASICs) or as a targeted netlist (FPGAs)
- Sophisticated self-checking Testbench
- Synthesis scripts.
- Simulation script, vectors and expected results.
- Comprehensive user documentation.