



SPI-MEM-CTRL

Serial Flash Controller Megafunction

The SPI-MEM-CTRL megafunction offers the interconnection between a host and a serial flash memory using the Serial Peripheral Interface. The SPI-MEM-CTRL supports Single, Dual Input, Dual Input/Output and Quad Input/Output SPI accesses.

The megafunction automatically identifies a variety of serial flash memories and communicates with the attached device at the maximum possible bandwidth. Register accesses are used to insert access requests and read/write data into/out SPI-MEM-CTRL megafunction. Communication with devices other than those automatically identified, is also feasible as the megafunction can be programmed with the memory device parameters. The SPI-MEM-CTRL can read, write or erase any part of the memory.

The megafunction is rigorously verified. A complete verification environment that helps designers verifies the functioning and compliance of the megafunction, and additional aids for system-level simulation are available.

Applications

The SPI-MEM-CTRL megafunction is suitable for any SoC design that uses a serial Flash device.

Block Diagram

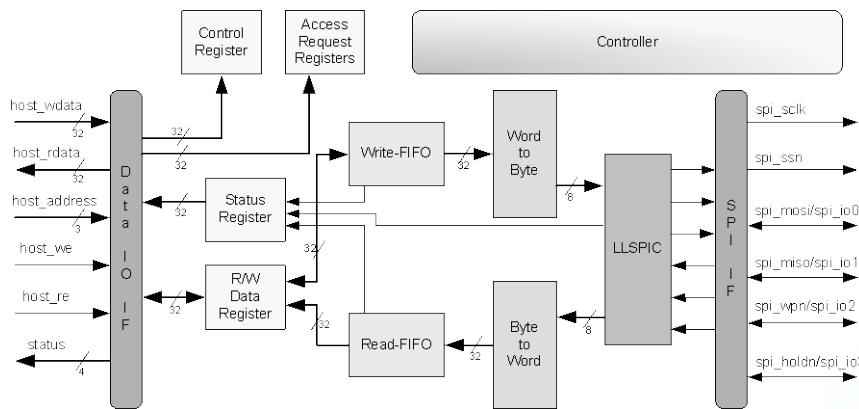

Features

Device Independent

- Automatic identification of a variety of memories
- Configurable memory features to allow support of more serial flash devices

Efficient Bandwidth Utilization

- Automatic identification of maximum bandwidth access mode among:
 - single SPI
 - dual output SPI
 - dual input / output SPI
 - quad input / output SPI

Flexible Access Model

- Registered Mapped I/O
 - Host issues access request, reads and writes data via registers access
- Read access sizes from 1 byte up to memory density
- Read accesses starting from any address offset
- Write access sizes from 4 bytes up to memory density
- Write accesses starting from any address offset that is multiple of 4
- Erasure of:
 - any sector (4KB)
 - any block (64KB)
 - whole chip

Ease of Integration

- Auto-detection of a wide set of serial flash devices to minimize programming overhead
- Auto detection of the fastest way to read or program the memory, to maximize bandwidth and minimize programming overhead
- Deep Power-down Mode support to minimize power consumption
- Optional APB interface

Design Quality

- Robust verification with integrated testbench environment.
- Scan-ready design

Functional Description

The host introduces the access request and the megafunc-tion begins communication with the serial flash. If the access request is a read then data from the memory is stored on a Read FIFO. The megafunc-tion will inform the host to read out data, once the number of bytes in the Read FIFO becomes larger than a programmable threshold. If the access request is a write, then data to be written in the serial flash memory are stored into a write FIFO. The megafunc-tion will inform the host to write data, once the Write FIFO can accept a number of bytes that is larger than a programmable threshold.

The SPI-MEM-CTRL megafunc-tion is programmed via host interface. When an access request is set, the controller de-codes it and sends the serial flash the necessary instructions to serve it. If the access request is a Read the LLSPIC reads data byte by byte using Single/Dual/Quad SPI. Then the data is forwarded in the Read FIFO. The host is signaled when there is enough data in it to take them out. Read access pauses if the Read FIFO gets full. If the access request is a write the LLSPIC sends the data inserted into the Write FIFO to the memory using Single/Dual/Quad SPI. The host is sig-naled when there is enough empty space in the Write FIFO to insert new data. If the Write FIFO gets empty the write process is paused. If the access request is an Erase the LLSPIC sends the serial flash the appropriate instruction in order to serve the request.

The megafunc-tion can automatically identify witch memory is attached among a list of chips supported. The megafunc-tion can be configured during synthesis to add one extra chip with similar behavior to those supported. Furthermore during run-time the host can program the megafunc-tion's behavior towards the serial flash attached if it is not one of those sup-ported.

Implementation Results

The SPI-MEM-CTRL utilizes FIFOs, the size of which is con-figurable during synthesis. The following are indicative Altera implementation results, for which all internal FIFOs are im-plemented with available SRAM resources.

Family Device	Logic	Fmax (MHz) core_clk/spi_sclk	Special Features
Cyclone-III EP3C5F256-C7	2,580 LEs	118 / 54	4 M9Ks
Stratix-III EP3SE50-C2	1,641 ALUTs	167 / 91	4 M9Ks
Stratix-IV EP4SGX230- C3ES	1,653 ALUTs	170 / 82	4 M9Ks
Arria II GX EP2AGX20-C4	1,653 ALUTs	186 / 69	4 M9Ks

Support

The megafunc-tion as delivered is warranted against defects for ninety days from purchase. Thirty days of phone and email technical support are included, starting with the first in-teraction. Additional maintenance and support options are available.

Verification

The SPI-MEM-CTRL megafunc-tion has been verified through extensive simulation and rigorous code coverage measure-ments.

Deliverables

The megafunc-tion includes everything required for successful implementation. The Altera version includes:

- Post synthesis EDIF
- Software (C++) Vector Generator
- Sophisticated HDL Testbench
- Simulation script, vectors and expected results
- Place and route script
- Comprehensive user documentation, including detailed specifications and a system integration guide