



I2S-APB

Inter-IC Sound Bus Megafunction for AMBA APB

The I2S-APB megafunction integrates eight channels of Inter-IC Sound compatible serial buses. I2S is a well-known stereo audio transmission standard, widely used to connect system elements such as Analog to Digital and Digital to Analog converters.

By using the I2S-APB module in a SoC design, a designer can easily integrate the megafunction used for multi-channel audio transmission with the master system based on a standard AMBA APB bus for further data processing. In order to facilitate the use of the I2S megafunction in AMBA bus based microprocessor systems, it is provided with an AMBA™ APB bus wrapper, transmit and receive FIFO control units, special function registers block (SFR), and 8-channels of the I2S megafunction.

The data collected by the I2S-APB megafunction is stored in the megafunction's internal FIFO. This use of an internal FIFO allows the system to process the relatively slow audio stream in the interrupt-triggered subroutines.

The collected data can then be easily and quickly accessed by the master system by the AMBA APB bus by any APB bus master.

Developed for reuse in ASIC and FPGA implementations, the design is strictly synchronous with two clock domains, positive-edge clocking in both domains (except of four flip-flops for reset signal synchronization). There are no internal tri-states and asynchronous resets, therefore scan insertion is straightforward.

Applications

The I2S-APB can be utilized for a variety of Inter-IC Sound compatible serial bus applications including:

- ASIC and SoC applications requiring up to 8 channel audio data transmission
- Connecting Analog to Digital and Digital to Analog converters with very low jitter
- Digital audio interface of embedded microcontroller systems
- Error correction for compact disc and digital recording
- Digital signal processing and multimedia systems in general

Block Diagram

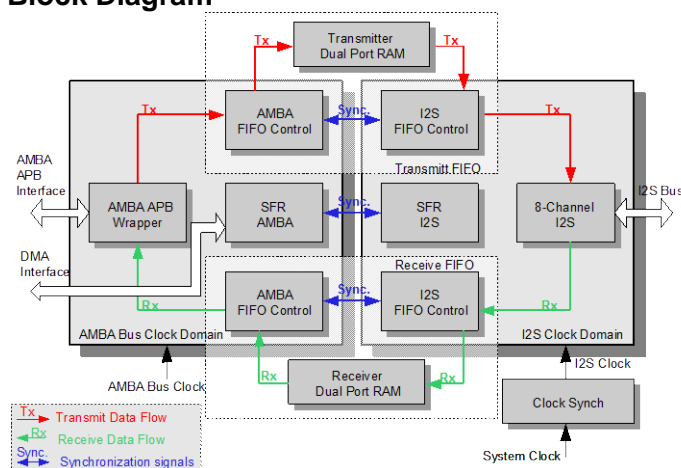

Features

- Meets Philips Inter-IC Sound Bus Specification
- Supported modes
 - I2S Philips
 - Left Justified
 - Right Justified
 - DSP
- Two clock domains
 - APB the host side clock domain
 - system clock for the I2S channels
- Eight configurable stereo channels
- Two sets of SCK (SCLK) and WS (LRCLK) strobes
 - one for all transmitters
 - one for all receivers
- AMBA™ APB bus slave interface for data and configuration
- Contains two configurable FIFO buffers
 - one for all transmit channels
 - one for all receive channels
- One configuration register block for all channels
- Interrupts driven by the I2S bus activity events
- Handshake interface to external DMA modules
- Sophisticated self-checking Testbench (Verilog versions use Verilog 2001)

Configurability

- Synthesis parameters allow adjustment to the target application

Functional Description

The I2S-APB megafunction is partitioned into modules as shown in block diagram above.

AMBA APB Wrapper

The APB bus slave wrapper, which is compatible with AMBA™ APB bus specification v.2.0, connects the SFR block and the FIFO buffers to the AMBA™ APB bus. The APB bus slave wrapper implements two APB bus slave interfaces that have separate select signals *pselsfr* and *pselfifo*, but share other bus signals. These slave interfaces will be henceforth denoted as APB SFR bus slave and APB FIFO bus slave.

8-Channel I2S

Each of the 8-channels of the I2S block can operate as either a transmitter or receiver. The mode of operation for a given channel can be set in the SFR block. There are two units in the megafunction that provide synchronization with the I2S bus for all channels. One of them provides synchronizing signals for all transmitters while another one provides synchronizing signals for all receivers.

The I2S Bus controller may operate in one of the following modes:

- Master Transmitter Mode: serial data is transmitted through SD while SCK and WS output serial clock and word select, respectively.
- Slave Transmitter Mode: serial data is transmitted via SD while serial clock and word select are input through SCK and WS, respectively.
- Slave Receiver Mode: serial data, serial clock and word select are received through SD, SCK and WS, respectively.
- Master Receiver Mode: serial data is received via SD while SCK and WS output serial clock and word select, respectively.

The I2S Bus Interface may operate in one of the following four configurations:

- I2S – Philips mode
- Let Justified mode (also known as DSP)
- Right Justified mode
- DSP mode

Every mode can be fixed by the set of synthesis parameters and cannot be changed after synthesis, but it is also available to set one of these modes to be a default mode and it can be still configurable by software.

SFR AMBA, SFR I2S

The Special Function Registers block is composed of two parts: SFR AMBA and SFR I2S. The former one belongs to the AMBA clock domain while the latter belongs to the I2S system clock domain. The SFR AMBA performs mandatory tasks of SFR while the SFR I2S provides the cross clock domain synchronization logic.

- The SFR is a set of nine 32bit registers that provides status of the I2S megafunction and FIFO buffers and allows for configuration of the megafunction. To address particular register for read/write operation three bit address bus is used. The SFR registers can be accessed only in the 32bit bus access mode.

AMBA FIFO Control, I2S FIFO Control

The AMBA FIFO Control and I2S FIFO Control components are two FIFO buffer controllers, together with two blocks of the DPRAM (1r1w) memory they make the data buffers. Both FIFO buffers are equipped with appropriate cross clock domain logic.

Transmitter and Receiver Dual Port RAM

The transmit RAM and Receive RAM component is a dual-port synchronous RAM (1r1w) memory. The memory module has two independent ports that enable parallel access to a single memory space, the size of the FIFO buffers can be chosen by the user, it can be set using synthesis parameters.

Clock Synch

The Clock Synch – is the clock synchronization for I2S channels. It includes clock gating logic for all channels. Each channel can be individually turned on/off by blocking clock signal for this channel. The clock signal can be blocked also for transmit or receive synchronization unit.

Implementation Results

I2S-APB reference designs have been evaluated in a variety of technologies. The following are sample Altera results for the core configured with a 16x24 FIFO and optimized for area.

Altera Device	LEs/ALUTs	Memory	Memory Bits	I/Os	Fmax (MHz)		Quartus
					APB	I2S	
Cyclone-II EP2C8-6	4,071	2 M4Ks	768	98	122	163	7.2
Cyclone-III EP3C10-6	4,067	2 M4Ks	768	98	112	178	7.2
Stratix-II EP2S15-3	2,537	2 M4Ks	768	98	151	271	7.2
Stratix-III EP3SL50-2	2,597	ALUTs 48	-	98	174	274	7.2

Support

The megafunction as delivered is warranted against defects for ninety days from purchase. Thirty days of phone and email technical support are included, starting with the first interaction. Additional maintenance and support options are available.

Verification

Functional verification of synthesizable megafunction is performed at VHDL/Verilog testbench. The top level of testbench contains synthesizable block of I2S-APB megafunction and additional environment modules like stimulus vectors generator and output vectors comparator.

Hardware verification of the prototype was realized with the aid of application demo. This application was developed on proprietary EB-3 Demo Board.

Deliverables

The megafunction includes everything required for successful implementation. The Altera version includes:

- Post-synthesis EDIF netlist
- Example design for I2S-APB (CHIP_I2S_APB)
- Sophisticated self-checking Testbench (Verilog versions use Verilog 2001)
- Simulation script, vectors, and expected results
- Place and route script
- Comprehensive user documentation, including detailed specifications and a system integration guide

CAST

info@cast-inc.com
www.cast-inc.com

CAST, Inc. 11 Stonewall Court
Woodcliff Lake, NJ 07674 USA
tel 201-391-8300 fax 201-391-8694
Copyright © CAST, Inc. 2009, All Rights Reserved.
Contents subject to change without notice.