

# CAST

## ALTERA®

### H8250

### Universal Asynchronous Receiver/Transmitter Megafunction

The H8250 is a standard UART providing 100% software compatibility with the popular Intel 8250 device. It performs serial-to-parallel conversion on data originating from modems or other serial devices, and performs parallel-to-serial conversion on data from a CPU to these devices.

Developed for easy reuse in ASIC and FPGA applications, the H8250 is available optimized for several technologies with competitive utilization and performance characteristics.

#### Applications

The H8250 can be utilized in a variety of UART applications including:

- Serial or modem computer interface
- Serial interface within modems and other devices

#### Block Diagram

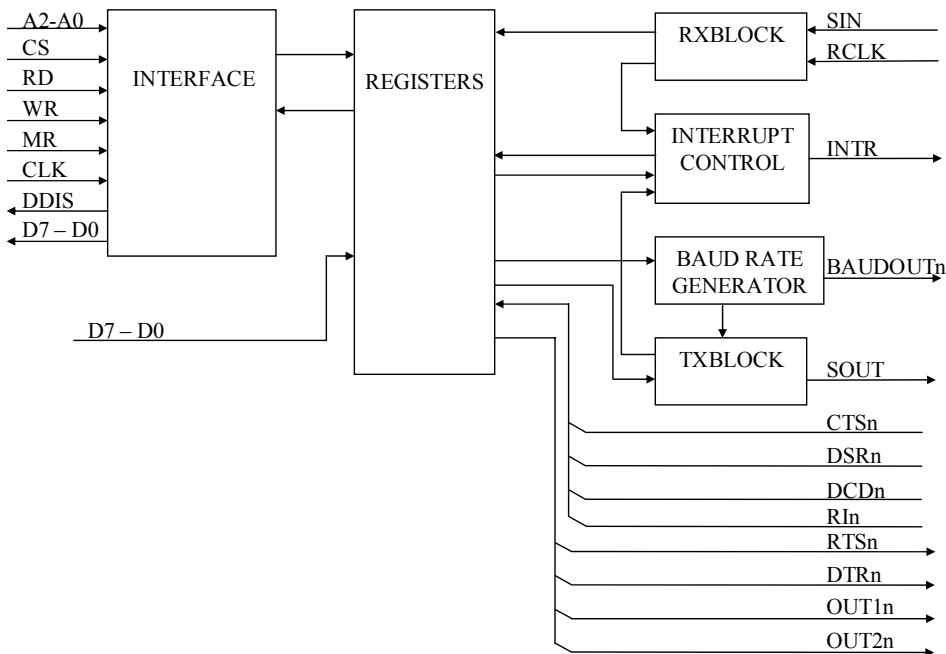

#### Features

- Capable of running all existing 8250 software
- Adds or deletes standard asynchronous communication bits (start, stop and parity) to or from the serial data
- Independently controlled transmit, receive, line status and data set interrupts
- Programmable baud generator divides any input clock by 1 to (216 - 1) and generates the 16 x clock
- Independent receiver clock input
- Modem control functions (CTS<sub>n</sub>, RTS<sub>n</sub>, DSR<sub>n</sub>, DTR<sub>n</sub>, RIn, and DCD<sub>n</sub>)
- Fully programmable serial interface characteristics:
  - 5, 6, 7, or 8 bit characters
  - Even, odd, or no-parity bit generation and detection
  - 1, 1½, or 2 stop bit generation
  - Baud generation
- False start bit detection
- Complete status register
- Internal diagnostic capabilities: loopback controls for communications link fault isolation
- Full prioritized interrupt system controls

## Functional Description

As shown in the Block Diagram and explained below, the H8250 includes six major blocks: Interface, Registers, RXBlock, Interrupt Control, Baud Rate Generator, and TXBlock.

### Interface

The Interface block is responsible for handling the communications with the processor (or parallel) side of the system. All writing and reading of internal registers is accomplished through this block.

### Registers

The Registers block holds all of the device's internal registers. See the Register Description table for details on existing registers and their addresses. Some information comes from the other blocks, but this is all gathered together in the Registers block and made available to all blocks.

### RXBlock

This is the receiver block. It handles the receiving of the incoming serial word. It is programmable to recognize data widths such as 5, 6, 7 or 8 bits, various parity settings such as even, odd or no parity and different stop bits of 1, 1½ and 2 bits. It checks for errors in the input data stream such as overrun errors, frame errors, parity errors and break errors. If the incoming word has no problems it is placed in the Receiver Holding register.

### Interrupt Control

The Interrupt Control block sends an interrupt signal back to the processor depending on the state of the received and transmitted data. There are various levels of interrupt which can be read from the Interrupt Identification register, which gives the level of interrupt. Interrupts are sent in the condition of empty transmission or receiving buffers, an error in the receiving of a character, or other conditions requiring the attention of the processor.

### Baud Rate Generator

This block takes the input clock, CLK, and divides it by a programmed value (from 1 to  $2^{16} - 1$ ). This divided clock is then divided by 16 to create the transmission clock called the Baudout clock. This clock can be connected to the input clock (RCLK) to provide it with a proper clock.

### TXBlock

The Transmit block handles the transmission of data written to the Transmission Holding register. It adds required start, parity and stop bits to the data being transmitted so that the receiving device can do the proper error handling and receiving.

## Component Substitution

The H8250 megafunction is modeled after the Intel 8250. The following points differentiate the H8250 from the Intel device. In order to create a megafunction with the same functions a wrapper is required. A sample wrapper is included.

- No provision is made for a crystal. The CLK input is designed to accept a standard digital input.
- The bi-directional Data Bus has been split into an input and an output component. In order to use the megafunction with a bi-directional Data Bus, the DDIS signal can be used as the controlling signal for the tri-state drivers.
- RD2, WR2, CS1 and CS2 have been eliminated. A single signal takes their place. These are RD, WR and CS.
- The ADSN signal has been removed. The H8250 functions as if the ADSN signal is held low. The included wrapper can be used to add the ADSN functionality latching the address and data buses.
- The main clock input CLK must be active from power-up.
- The Baudrate Generator is reset to the 0001h value upon activation of the MR signal. Programming the BRG to 0000h is an illegal value. The minimum value for the BRG is 0001h. The Output Data Bus always shows the value of the last register read.

## Implementation Results

H8250 reference designs have been evaluated in a variety of technologies. The following are sample Altera results optimized for speed, and assuming all megafunction I/Os are routed off-chip.

Supported Family	Utilization			Fmax
	LEs	Memory	Memory bits	
Flex EPF10K30E-1	405	-	-	126 MHz
Apex EP20K30E-1	403	-	-	141 MHz
Acex EP1K10-1	405	-	-	126 MHz

## Support

The megafunction as delivered is warranted against defects for three years from purchase. Thirty days of phone and email technical support are included, starting with the first interaction. Additional maintenance and support options are available.

## Verification

The megafunction has been verified through extensive simulation and rigorous code coverage measurements.

## Deliverables

The megafunction is available in ASIC (synthesizable HDL) and FPGA (netlist) forms, and includes everything required for successful implementation. The Altera version includes:

- Post-synthesis EDIF netlist
- Testbench (self checking)
- Wrapper for pin compatible replacement
- Simulation script, vectors, expected results, and comparison utility
- Place and route script
- Comprehensive user documentation, including detailed specifications and a system integration guide